

ELHR-12V-55AH 12V 55Ah (Recessed)

General Application

12VC55 is a high performance battery with 4~6 years in standby service or more than 500 cycles at 50% depth of discharge in cycle service.

Specification

● NOMINAL VOLTAGE	: 12 V
● NOMINAL CAPACITY(20 hr)	: 55.0 Ah
● DIMENSIONS	
TOTAL HEIGHT	: 225 mm (8.86 inches)
CONTAINER HEIGHT	: 207 mm (8.15 inches)
LENGTH	: 229 mm (9.02 inches)
WIDTH	: 138 mm (5.43 inches)
● WEIGHT	: APPROX 19 Kg (41.89 lbs)
● CONTAINER MATERIAL	: UL94HB ABS
	: UL94V-0 ABS
● INTERNAL RESISTANCE(25°C , 77 °F)	: ~8mΩ
● DISCHARGE CAPACITY UNDER DIFFERENT TEMPERATURES	
40°C	: ~102%
25°C	: ~100%
0 °C	: ~85%

Characteristics

● CAPACITY 25 °C / 77 °F	
20 hr @ 2.75 A	: 55.0 Ah
5 hr @ 8.8A	: 44.0 Ah
1 hr @ 33 A	: 33.0 Ah
1 C @ 55 A	: 27.5 Ah
● CHARGING VOLTAGE (25°C , 77 °F)	
STANDBY USE	: 13.65V ± 0.15 V
CYCLE USE	: 14.7V ± 0.3 V
● MAX DISCHARGE CURRENT	: 600 A (5 sec)
● MAX CHARGING CURRENT	: 16.5 A
● SELF-DISCHARGE RESIDUAL CAPACITY(25°C , 77 °F)	
AFTER 3 MONTHS	: ~90%
AFTER 6 MONTHS	: ~82%
AFTER 12 MONTHS	: ~70%

Discharge Current vs Time

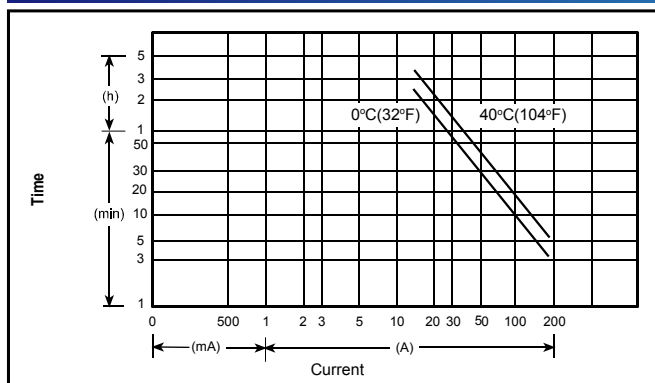

Discharge Characteristics @25 °C (77 °F)

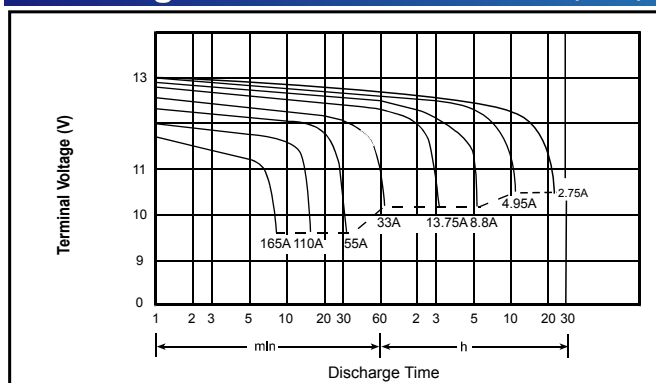

Dimensions

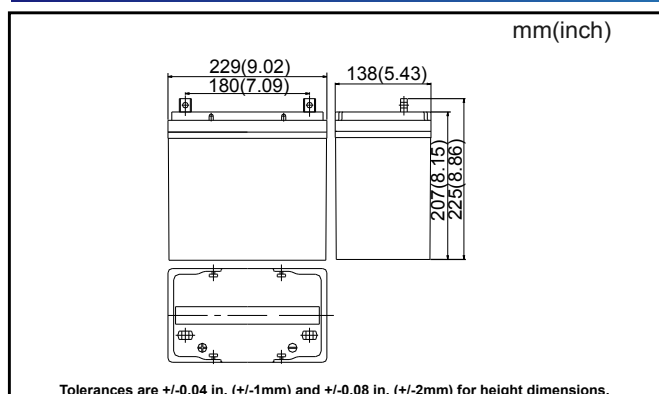

Terminal

