

Project/Location:  
 \_\_\_\_\_  
 Contractor:  
 \_\_\_\_\_  
 Date:  
 \_\_\_\_\_  
 Prepared by:  
 \_\_\_\_\_

# EF30 Series

## Remote Fixture



### FEATURES

- Sealed beam, surface-mounted, rubber coated industrial remote fixture
- For use in high pressure hose down areas
- Available only in black
- Certified CSA C22.2 No.141

### REPLACEMENT LAMPS

MODEL	LAMP TYPE	VOLTAGE-WATTAGE
550.0026-E	Tungsten	12V-12W
550.0027-E	Tungsten	12V-18W
550.0023-E	Tungsten	12V-25W

\*Lamps for RS10QWPBH.  
 For the complete list, please see the lamp chart on pages 156 to 158



### DIMENSIONS

Dimensions are approximate and subject to change.

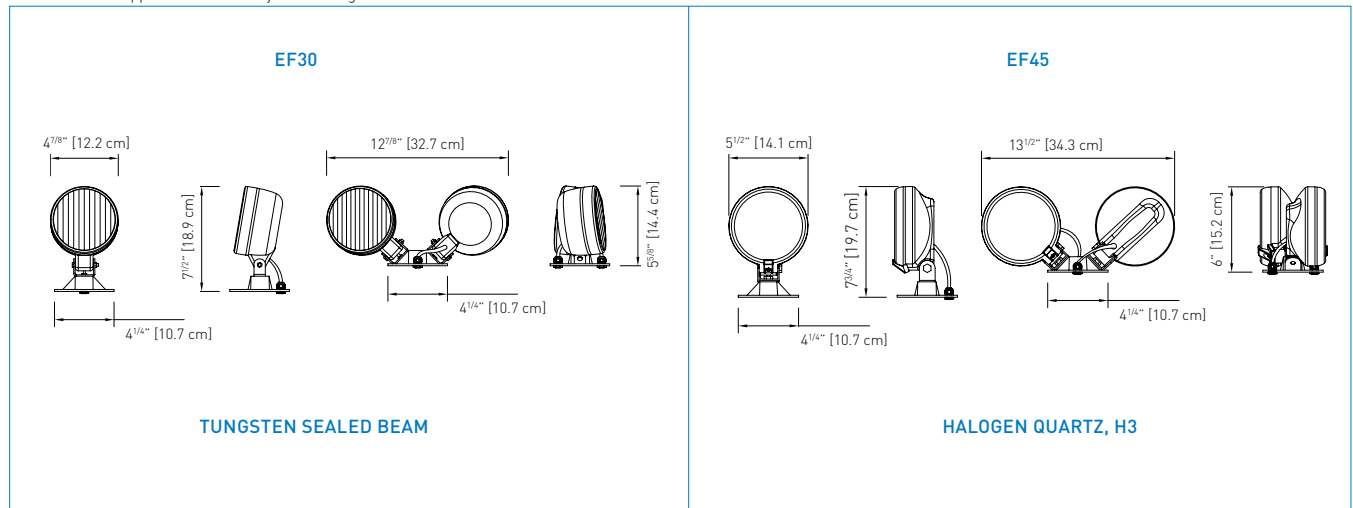

### ORDERING INFORMATION

SERIES	LAMP STYLE	VOLTAGE	OPTIONS
EF30= single PAR 36 EF30D= double, PAR 36	S= tungsten sealed beam H=halogen sealed beam	-6V__W= tungsten, 6V - 8, 12, 18 or 25W, sealed beam -12V__W= tungsten, 12V - 12, 18 or 25W, sealed beam -6V__W= halogen, 6V - 8, 12 or 20W, sealed beam -12V__W= halogen, 12V - 8, 12 or 37W, sealed beam	FP= teflon coated lens
		*NOTE: "__" = insert wattage required.	

EXAMPLE: EF30S-6V9W

### ORDERING INFORMATION

SERIES	VOLTAGE
EF45Q= single EF45DQ= double	-12V55W= halogen, 12V - 55W, H3 -24V70W= halogen, 24V - 70W, H3

EXAMPLE: EF45QS-12V55W