

EMEX

Central Battery Systems
Emergency Lighting



Table of Content

General Presentation	3 & 4
Single Phase Systems	5 & 6
Three Phase Systems	7 & 8
Optional Features	9
User Interface and Display	10
What to consider when requesting a Central System?	11

Choosing the right system

There are a variety of ways in which back-up power can be provided. However, even though certain methods are suitable for critical applications, they may not necessarily be suitable for Emergency Lighting.

This is because an Emergency Lighting system has unique load characteristics. And since Emergency Lighting is a critical life-safety installation, it is vital that a Central Battery System is designed with these load characteristics in mind.

EMEX Power central inverter systems are specifically designed to provide emergency power for emergency lighting systems in a power failure.



In choosing the right AC system to support emergency lighting it is important to consider the following questions:

Overload performance

Is the system able to start the full load without the mains supply present. How does the system perform in a total power failure (ie is the system able to start the load without the bypass supply being available)?

Repeat duty

CSA141-10 requires a central battery system to fully recharge within 24 hours. Is the charger able to recharge the batteries quickly (80% in 14 hours or 100% after 24 hours)?

Energy consumption and heat dissipation

Are the inverter and charger permanently running, shortening the battery life, generating heat, wasting energy and shortening component life?

Are cooling fans running continuously, generating noise?

Maintenance

Is the system easy to service and maintain? Is the system designed in a modular format, or would the failure of even a minor component require the whole system to be shut down and stripped for repair?.

General information on UPS systems:

Recharge period

UPS systems which are designed primarily for computer back-up generally offer short run times, 5 or 10 minutes. The long run times required for emergency lighting call for more powerful chargers to recharge the larger bank of batteries needed in the time prescribed by CSA.

Overload performance

An emergency lighting load will impose large "in-rush" currents when starting lamps from cold. However, UPS systems are often designed to shut down at only 125% overload and revert to the incoming supply. During a total power failure situation, this could result in total failure of the emergency lighting system. Furthermore, a UPS may fail to clear a breaker on a lighting circuit, meaning that a single short circuit fault could result in loss of the entire emergency lighting supply.

Energy consumption and battery life

Most UPS systems operate in the "on-line" mode, whereby the inverter runs constantly to supply the load, and power is taken from the battery with the charger running constantly. This places an excessive ripple on the battery (contrary to the advice given by most battery manufacturers). Also, the system is constantly generating heat which has a further detrimental effect on battery life. There are energy costs and heat generation issues must be addressed when running an on-line system.

EMEX Power - Modular AC Central Battery System

SYSTEM DESIGN

The **EMEX Power** inverter and charger modules utilize solid state electronics of the highest reliability to provide a rugged, easy to maintain system with exceptional performance for emergency lighting use. The system has been designed solely for emergency lighting, and not modified from other less essential power supply requirements. As such, the system has exceptional overload performance without the need to over-specify the rating of the inverter to ensure faults can be cleared.

Each module has input and output protection and each module measures and limits its own current.

Alarms and status indications are provided on the front panel display, which provide clear and concise information, rather than a long list of parameters, which may be confusing.

SERIES HIGHLIGHTS

Performance

The EMEX-Power Systems work with lighting loads to provide full light output for minimum 30 min. It is designed to support incandescent, fluorescent and LED loads. It will power these loads at cold starts for all normally off circuits or normally on circuits.

True Sine Waveform

Using a solid-state, pulse width modulation (PWM) inverter, the systems produce pure sinusoidal output waveform with less than 5% Total Harmonic Distortion (THD) for linear loads.

Reliability

The product is third generation inverter technology. LVD (Low Voltage Disconnect) circuitry eliminates excessive battery drain after long power outages.

Batteries

Automatic restart and recharge upon restoration of utility.

Approvals

- CSA C22.2 No. 141-10 – Emergency Lighting Equipment
- CSA C22.2 No. 107.3 – Uninterruptible Power Systems
- UL 1778 – Uninterruptible Power Systems

Applications

EMEX-Power Systems can be used in almost every type of building, especially in architecturally sensitive applications or when maintenance costs and testing of individual unit equipment becomes significant. Our systems are designed to work with power factor corrected as well as the most recent T5 and T5-HO electronic ballasts.

FEATURES

BENEFITS

Self-Diagnostic/Self-Testing

Programmable monthly and annual self-testing. Proven self-diagnostic with information stored in separate memory logs for Test, Event and Alarm. Microprocessor monitoring and control.

Low heat dissipation

Very low heat loss in standby operating mode (see specifications for exact values). Convection cooling in normal mode with forced air during emergency and recharge mode. Battery cabinets: convection cooling only.

Versatile Installation

Modular design, easy front access freestanding cabinets, fasten together when more than one cabinet is required. Optional seismic kit available. All wiring provided is pre-cut and terminated, along with the necessary hardware for proper installation.

Complete Protection

Battery circuit breakers are standard. Modular standard systems offer overload capacity, short-circuit protection, current-limiting, low-battery disconnect and brownout protection as standard.

Thermal Performance

Bonded oversized heat sinks for maximum thermal performance. Cooling fans are energized only in inverter and recharge modes.

Monitoring and Control

User friendly programmable interface with LCD display provides full metering values, easy program and control functions and a wide range of visual and audible alarms.

Compliance with NFPA101

The self-testing meets the requirements of NFPA and UL. User programmable time of testing. Test results, events or alarms can be downloaded from history logs. Load monitoring. Reduced testing/service time.

Less air-conditioning

Reduced costs for air-conditioning required to ensure the optimum operating temperature when compared with equivalent systems that dissipate much more heat. Higher reliability of fans and electronic components.

Easy to install

Quick installation and connection through flexible cable entries and fast access terminal blocks. Low MTTR (<30 min.) due to modular design, quick disconnect means and frontal access.

Reduced damage risks

The full protection of the system will eliminate damage created by external events and will increase lifetime of the electronics and the batteries.

Increased MTBF

Increased reliability and reduced preventative maintenance. No air filters needed.

Easy maintenance

Diagnostics, troubleshooting, preventative maintenance and service are made easier by using the front panel display or the history logs.

EMEX Central Battery Systems IPS SINGLE PHASE SERIES

Interruptible emergency lighting inverter system 3KVA –15KVA



For all fluorescent/incandescent/LED loads

Features:

- PWM/Power Mosfet technology
- Self-testing/Self-diagnostic
- User programmable with password protection
- User programmable variable time delay
- Optional 100% normally Off output
- RS485 MODBUS RTU communication port
- Micro-processor controlled
- 30, 60, 90, 120 minutes run times
- Summary alarm form C dry contact
- Generator compatibility
- Electronic and magnetic ballast compatible
- Automatic event, test and alarm log
- LCD display
- Maintenance free standard batteries
- Forced air cooling during emergency and recharge mode only
- Off when on standby



ELECTRICAL/MECHANICAL CHARACTERISTICS for 30 minutes back-up time

Power rating KVA/KW	Effic. at full load %	Max. input current (A) ⁽¹⁾				Heat loss in normal mode (BTU/hr)	Batt. VDC	Batt. ADC	No. of batt. ⁽¹⁾	IPS cabinet dimensions			No. of batt. cab. (1)(2)	Batt. cabinet dimensions			IPS Cabinet weight kg ⁽¹⁾	Batt. cabinet weight kg (empty) ⁽¹⁾	Battery weight kg ⁽¹⁾	Total system weight kg ⁽¹⁾
		120V	240V	277V	347V					W"	H"	D"		W"	H"	D"				
3.0	98%	42	21	18	14	546	120	34	10	30	71	27	NA	NA	NA	NA	240	NA	105	345
6.0	98%	67	33	29	23	546	120	68	20	30	71	27	NA	NA	NA	NA	290	NA	210	500
9.0	98%	92	46	40	32	546	120	101	10	30	71	27	NA	NA	NA	NA	340	NA	372	712
12.0	98%	117	58	51	40	546	120	135	20	30	77	27	1	30	77	27	390	140	550	1080
15.0	98%	142	71	61	49	546	120	168	20	30	77	27	1	30	77	27	440	140	550	1130

1- For 30 min. discharge time. For other discharge times, consult factory.

2- Batteries are installed in the IPS cabinet for 3 to 9.0KVA systems, for 30 minutes only.

Ordering Information⁽¹⁾

Series	System Voltage	KVA/KW	Run Time	External Circuit Breaker	Options
E= Series	1 = 120-120 input-output 2 = 120/240-120/240 (3 wire in-out) 3 = 277-277 4 = 347-347	A = 3 B = 6 C = 9 D = 12 E = 15*	3 = 30 minutes 6 = 60 minutes 9 = 90 minutes 12 = 120 minutes	B = no breakers N#### = normally on F#### = normally off First two digits= Qty. 01 to 99 max (specify) Last two digits= Amp rating 10, 15, 20, 25... (specify)	A = fast recovery charge C = remote alarm panel E = output trip alarm G = "inverter on" dry contact H = normally off full capacity output I = extended battery warranty* J = external maintenance bypass K = anchor mounting bracket L = drip shield M = second output terminal block N = normally on & normally off output**
	* Other voltages available using external transformer (sold separately)	* For 120 minutes run time, minimum 120/240VAC in/out		Example :N1020 **	* Consult your sales representative. ** Full capacity available on either output

Example: E1A3N1020

EMEX Central Battery Systems IPS SINGLE PHASE SERIES

SYSTEM SPECIFICATIONS

General

Design	Stand-by, PWM inverter type utilizing Power Mosfet technology with 500ms transfer time.
Control	Microprocessor controlled, 4 x 20-character display with touch pad controls & functions
Metering	Input & Output Voltage, Battery Voltage, Battery & Output Current, Output VA, Temperature
Communications	RS-485 MODBUS RTU Port (DB-9) Baud rate 19200 b.p.s

Electrical Input

Voltage	120, 277, 347VAC 2-wire or 120/240VAC 3-wire, 1-phase, +10%/ -15%
Input Frequency	60Hz

Electrical Output

Voltage	120, 277, 347VAC 2-wire or 120/240 3-wire, 1-phase
Dynamic Voltage	+/-2% for +/-25% load step change, +/-3% for a 50% load step change, recovery within 3 cycles
Harmonic Distortion	<5% THD for linear load
Output Frequency	60Hz +/- 2Hz during emergency mode
Load Power Factor	0.7 lag to 0.9 lead
Inverter Overload	120% continuous, 150% for 1 minute and 200% for 10 seconds
Protection	Optional External Distribution Circuit Breaker
Crest Factor	3

Environmental Conditions

Storage/Transport	32°F to 104°F (0°C to 40°C) without batteries 68°F to 86°F (20°C to 30°C) with batteries ⁽¹⁾
Operating Temperature	System operates safely from 32°F to 104°F (0°C to 40°C) but optimum operation is between 68° F and 77°F (20°C to 25°C). Battery performance can be affected by temperature.
Altitude	<10,000 feet (above sea level) without de-rating
Relative Humidity	0 to 95% non-condensing
Audible Noise	45 dBA at 1m from surface in emergency mode

(1) - max. 3 months at 77°F-86°F (25°C-30°C)

Single Line Diagram

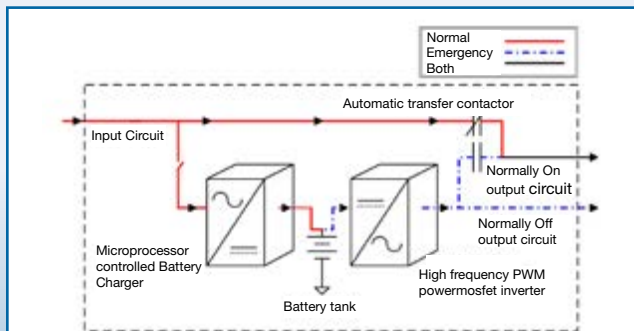

CABINETS

Modular design, freestanding NEMA type 1 steel cabinets powder coated for corrosion and scratch resistance. Front access design through hinged lockable doors requires only 42" front, 2" back and side clearance and 12" top clearance without drip shield. Top conduit entry Gland Plate.

INVERTER

Using Power Mosfet/PWM technology the inverter converts DC voltage supplied by the batteries to AC voltage of a precise stabilized amplitude and frequency, suitable for most sophisticated electrical equipment. True sinusoidal output waveform with very low distortion (less than 5% for linear loads). Overload capability of 120% continuous, 150% for 1 minute and 200% for 10 seconds.

CHARGER

Fully automatic, temperature compensated, charger recharges fully discharged batteries in maximum 24 hours at nominal AC input voltage. AC input current limiting and over-voltage protection included.

BATTERY

System is provided standard with 10 year, maintenance free, sealed valve regulated, lead calcium batteries. 30, 60, 90 & 120 min. standard discharge time at full load under normal operating temperature (20°C to 25°C). Low Voltage Disconnect protection included. No special ventilation required.

SUPERVISION

Automatic self tests consist of a 2-minute monthly, 1/3 discharge at 6 months and full annual discharge.

The front-mounted control panel includes, a 4-line 20-character LCD display with a keypad to control and monitor the operation of the system. This allows the operator to easily "watch" system functions as they occur and check on virtually any aspect of the system's operation. Standard RS485 MODBUS RTU diagnostic interface.

ALARMS

Battery High/Low, Low Voltage Disconnect, Battery Disconnect, Maintained Lamp Off, Charger Fail, Supply From Battery, System Inhibit, Circuit Breaker Trip, Module Breaker Trip, Inverter Undervoltage, Inverter Overvoltage, Output Overcurrent, Hi Temp, Over Temp, Unit in Bypass, Inverter Frequency Control Failed, Processor Reset.

OPTIONAL FEATURES

External Output Circuit Breakers, Output Trip Alarms, Extended Battery Warranty, 12 Hours Fast Recharge, External Maintenance Bypass Switch, Dripshield, Remote Alarm Panel, Normally Off Output, Anchor Mounting Brackets, Dry Contact Relay.

FACTORY START-UP

Includes one additional year of warranty. See warranty conditions.

WARRANTY

(full limited warranty conditions available upon request)

Limited manufacturer warranty is one-year, parts and labor, for system electronics. Battery warranty is one year full plus 9 years pro-rata for a total of 10 years, under normal operating conditions. System must be put in service within 6 months from ship date in order to validate warranty.

Consult factory for other battery types.

EMEX Central Battery Systems IPS THREE PHASE SERIES

Interruptible emergency lighting inverter system 4.5KVA –54KVA



For all fluorescent/incandescent/LED loads

Features:

- PWM/Power Mosfet technology
- Self-testing/Self-diagnostic
- User programmable with password protection
- User programmable variable time delay
- Optional 100% normally Off output
- RS485 MODBUS RTU communication port
- Micro-processor controlled
- 30, 60, 90, 120 minutes run times
- Summary alarm form C dry contact
- Generator compatibility
- Electronic and magnetic ballast compatible
- Automatic event, test and alarm log
- LCD display
- Maintenance free standard batteries
- Forced air cooling during emergency and recharge modes only
- Off when on standby



ELECTRICAL/MECHANICAL CHARACTERISTICS for 30 minutes back-up time

Power rating KVA/ KW	Effic. at full load %	Max. input current (A) ⁽¹⁾			Heat loss in normal mode (BTU/hr)	Batt. VDC	Batt. ADC	No. of batt. ⁽¹⁾	No. of IPS cab. ⁽¹⁾⁽²⁾	IPS cabinet dimensions			No. of 20 batt. cab. ⁽¹⁾⁽²⁾	Batt. cabinet dimensions			No. of 30 batt. cab. ⁽¹⁾⁽²⁾	Batt. cabinet dimensions			Total IPS Cabinet weight kg ⁽¹⁾⁽²⁾	Total batt. cabinet weight kg (empty) ⁽¹⁾	Battery weight kg ⁽¹⁾	Total system weight kg ⁽¹⁾
		208/ 120V	480/ 277V	600/ 347V						W"	H"	D"		W"	H"	D"		W"	H"	D"				
4.5	98%	29	13	10	546	120	50	20	1	30	71	27	NA	NA	NA	NA	NA	NA	NA	265	NA	210	475	
9.0	98%	42	18	14	546	120	101	10	1	30	71	27	NA	NA	NA	NA	NA	NA	NA	340	NA	372	712	
13.5	98%	54	23	19	546	120	151	20	1	30	77	27	1	30	77	27	NA	NA	NA	415	140	550	1105	
18.0	98%	67	29	23	546	120	202	20	1	30	77	27	1	30	77	27	NA	NA	NA	540	140	744	1424	
22.5	98%	79	34	27	546	120	252	30	1	30	77	27	NA	NA	NA	NA	1	30	71	30	615	165	825	1605
27.0	98%	92	40	32	1092	120	303	30	1	30	77	27	NA	NA	NA	NA	1	30	77	30	690	165	1116	1971
31.5	98%	104	45	36	1092	120	353	30	2	30	77	27	1	30	77	27	NA	NA	NA	905	140	1116	2161	
36.0	98%	117	51	40	1092	120	403	40	2	30	77	27	NA	NA	NA	NA	1	30	77	30	1030	165	1488	2683
40.5	98%	129	56	45	1092	120	454	40	2	30	77	27	2	30	77	27	NA	NA	NA	30	1105	280	1488	2873
45.0	98%	142	61	49	1092	120	504	50	2	30	77	27	1	30	77	27	1	30	77	30	1180	305	1860	3345
49.5	98%	NA	67	53	1092	120	555	50	2	30	77	27	1	30	77	27	1	30	77	30	1255	305	1860	3420
54.0	98%	NA	73	58	1638	120	605	60	2	30	77	27	NA	NA	NA	NA	2	30	77	30	1380	330	2232	3942

1- For 30 min. discharge time. For other discharge times, consult factory.

2- Batteries are installed in the IPS cabinet for 4.5 to 9.0KVA systems, for 30 minutes only.

Ordering Information⁽¹⁾

Series	System Voltage	KVA/KW	Run Time	External Circuit Breaker	Options
EIII = Series	1 = 120/208 4 wire in-out 2 = 277/480 3 = 347/600	A = 4.5 B = 9 C = 13.5 D = 18 E = 22.5 F = 27 G = 31.5 H = 36 I =40.5 J = 45** K = 49.5* L = 54*	3 = 30 minutes 6 = 60 minutes 9 = 90 minutes 12 = 120 minutes	B = no breakers N#### = normally on F#### = normally off First two digits= Qty. 01 to 99 max (specify) Last two digits= Amp rating 10, 15, 20, 25... (specify)	A = fast recovery charge C = remote alarm panel E = output trip alarm G = "inverter on" dry contact H = normally off full capacity output I = extended battery warranty* J = external maintenance by pass K = anchor mounting bracket L = drip shield M = second output terminal block N = normally on & normally off output**
	* Other voltages available using an external transformer (sold separately)	* Min. 277/480Vac in/out ** For 120/208Vac in/out, 120 mins. runtime not available.		Example: N1020	* Consult your sales representative. ** Full capacity available on either output

Example: EIII1A3N1020

EMEX Central Battery Systems IPS THREE PHASE SERIES

SYSTEM SPECIFICATIONS

General

Design	Stand-by, PWM inverter type utilizing Power Mosfet technology with 500ms transfer time.
Control	Microprocessor controlled, 4 x 20-character display with touch pad controls & functions
Metering	Input & Output Voltage, Battery Voltage, Battery & Output Current, Output VA, Temperature
Communications	RS-485 MODBUS RTU Port (DB-9) Baud rate 19200 b.p.s

Electrical Input

Voltage	120/208, 277/480, 347/600VAC 3-phase 4-wire +10% / -15%.
Input Frequency	60Hz

Electrical Output

Voltage	120/208, 277/480, 347/600VAC 3-phase 4-wire.
Dynamic Voltage	+/-2% for +/-25% load step change, +/-3% for a 50% load step change, recovery within 3 cycles
Harmonic Distortion	<5% THD for linear load
Output Frequency	60Hz +/- 2Hz during emergency mode
Load Power Factor	0.7 lag to 0.9 lead
Inverter Overload	120% continuous, 150% for 1 minute and 200% for 10 seconds
Protection	Optional External Distribution Circuit Breaker
Crest Factor	3

Environmental Conditions

Storage/Transport	32°F to 104°F (0°C to 40°C) without batteries 68°F to 86°F (20°C to 30°C) with batteries ⁽¹⁾
Operating Temperature	System operates safely from 32°F to 104°F (0°C to 40°C) but optimum operation is between 68° F and 77°F (20°C to 25°C). Battery performance can be affected by temperature.
Altitude	<10,000 feet (above sea level) without de-rating
Relative Humidity	0 to 95% non-condensing
Audible Noise	45 dBA at 1m from surface in emergency mode

(1) - max. 3 months at 77°F-86°F (25°C-30°C)

Single Line Diagram

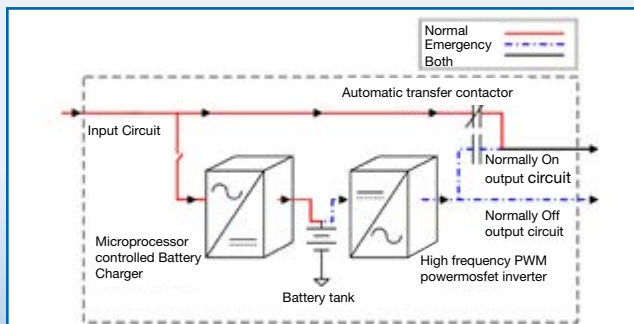

CABINETS

Modular design, freestanding NEMA type 1 steel cabinets powder coated for corrosion and scratch resistance. Front access design through hinged lockable doors requires only 42" front, 2" back and side clearance and 12" top clearance without drip shield. Top conduit entry Gland Plate.

INVERTER

Using Power Mosfet/PWM technology the inverter converts DC voltage supplied by the batteries to AC voltage of a precise stabilized amplitude and frequency, suitable for most sophisticated electrical equipment. True sinusoidal output waveform with very low distortion (less than 5% for linear loads). Overload capability of 120% continuous, 150% for 1 minute and 200% for 10 seconds.

CHARGER

Fully automatic, temperature compensated, charger recharges fully discharged batteries in maximum 24 hours at nominal AC input voltage. AC input current limiting and over-voltage protection included.

BATTERY

System is provided standard with 10 year, maintenance free, sealed valve regulated, lead calcium batteries. 30, 60, 90 & 120 min. standard discharge time at full load under normal operating temperature (20°C to 25°C). Low Voltage Disconnect protection included. No special ventilation required.

SUPERVISION

Automatic self tests consist of a 2-minute monthly, 1/3 discharge at 6 months and full annual discharge.

The front-mounted control panel includes, a 4-line 20-character LCD display with keypad to control and monitor the operation of the system. This allows the operator to easily "watch" system functions as they occur and check on virtually any aspect of the system's operation. Standard RS485 MODBUS RTU diagnostic interface.

ALARMS

Battery High/Low, Low Voltage Disconnect, Battery Disconnect, Maintained Lamp Off, Charger Fail, Supply From Battery, System Inhibit, Circuit Breaker Trip, Module Breaker Trip, Inverter Undervoltage, Inverter Overvoltage, Output Overcurrent, Hi Temp, Over Temp, Unit in Bypass, Inverter Frequency Control Failed, Processor Reset.

OPTIONAL FEATURES

External Output Circuit Breakers, Output Trip Alarms, Extended Battery Warranty, 12 Hours Fast Recharge, External Maintenance Bypass Switch, Dripshield, Remote Alarm Panel, Normally Off Output, Anchor Mounting Brackets, Dry Contact Relay.

FACTORY START-UP

Includes one additional year of warranty. See warranty conditions.

WARRANTY

(full limited warranty conditions available upon request)

Limited manufacturer warranty is one-year, parts and labor, for system electronics. Battery warranty is one year full plus 9 years pro-rata for a total of 10 years, under normal operating conditions. System must be put in service within 6 months from ship date in order to validate warranty.

Consult factory for other battery types.

Systems Options -DETAILS-

(-A) 12 Hour Fast Recharge

Battery charger upgrade option which decreases the time required to recharge a fully discharged battery to a fully charged state. The normal 24 hour recharge time is reduced to a 12 hour period.

(-C) Remote Summary Alarm Panel

Wall mountable box provides visual and audible alarms with silence switch. The panel consists of LED indicators and built in audible alarm and may be located up to 1,000 feet away from the inverter system.

(-E) Output Trip Alarm

System triggers an alarm when any output breaker trips.

(-G) Inverter On Dry Contacts

Form C dry contacts that will change state when the system transfers to battery.

(-H) Normally Off Output

This output circuit is dedicated for the emergency only equipment. Emergency only equipment operates during power outages and when the system is on battery back up. This option leaves the normally off load circuits off during normal utility power conditions.

(-I) Extended Battery Warranty

Extends battery warranty from 10 years pro-rated to 20 years pro-rated.

(-J) External Maintenance Bypass Switch

The external maintenance bypass switch is mounted in a 20"H x 16"W x 9"D NEMA 1 separate enclosure, used to completely isolate the inverter system from the connected load and AC utility input. This option allows the system to be safely powered down for maintenance or service.

(-K) Anchor Mounting Kit

The anchor mounting kit option is designed to prevent system movement. Heavy duty brackets are provided to secure system cabinetry to your surfaces.

(-L) Drip Shield

Hood cover to protect the enclosure against falling water from sprinkler systems.

(-M) Second Output Terminal Block

The output of the Central System is divided into two. The load can be connected to either outputs.

(-N) Normally On & Normally Off Outputs

The Central System can have both normally on and normally off outputs. Either output can handle 100% of the load.

User Interface & Display Functions

Meter & Reading Functions Menu

- AC Voltage Output
- AC Current Output Normally On
- AC Current Output Normally Off
- Battery Voltage
- Battery Charging Current
- Battery Discharging Current
- KVA Total Output
- Cabinet Internal Temperature
- Inverter Frequency
- Real Time Clock
- Time Delay
- Monthly Test Result
- Half Year Test Result
- Annual Test Result
- Event Log Reading

Service Menu Functions

- Passkeyword protected
- Set Battery Voltage & Current Ranges
- Set System Voltage & Current Ranges
- Set System Phase
- Set Normally OFF Load
- Set Language
- Set Real Time Clock & Calendar
- Set Time Delay Function
- Set Manual Test Duration
- Set Self Test Sequence
- Set Buzzer Function



Administration Menu Functions

- Passkeyword protected
- Read/Set Serial Number
- Read/Set Manufacturing Date
- Read/Set Installation Date
- Read Firmware Version
- Read/Clear Battery Elapse Time
- Read/Clear Total Power Failures
- Read/Clear Total Alarms
- Clear Event Log
- Enter Calibration Routine

Alarm and Events

- Event Logging (1000) Type Date & Hour
- Transfer Mode
- Standby
- Load Off
- Stop Mode
- Lock-Out Mode
- Forced Transfer
- Battery Volt
- Battery Disconnect
- Mains Out Of Range
- Manual Test
- Monthly Test
- Half Year Test
- Yearly Test
- Modbus Transfer
- NEXUS® Transfer

System Testing

EMEX Central Battery Systems provide manual and automatic test functions. Manual test can be activated any time using the test key provided on the control panel. Manual testing will do a programmable fixed test time and can be aborted any time by pushing again on the test key. Automatic test and diagnostic is done following an annual sequence. Every month a quick diagnostic test of 2 minutes is performed. At the 6 month mark, a 1/3 timed discharge test is done, and at the 12 month, a full discharge, down to LVD is performed. Pass/Fail and discharge time are registered in the event log. Test time and date is programmed using the Service Menu.

Central System Request Data

1) Input voltage

Single phase	(2 wire + ground)	120VAC <input type="checkbox"/>	208VAC <input type="checkbox"/>	277VAC <input type="checkbox"/>	347VAC <input type="checkbox"/>
Single phase	(3 wire + ground)	120/240VAC <input type="checkbox"/>			
Three phase	(4 wire + ground, Y)	120/208VAC <input type="checkbox"/>	277/480V <input type="checkbox"/>	347/600VAC <input type="checkbox"/>	
Three phase	(3 wire + ground, Δ)	208VAC <input type="checkbox"/>	480VAC <input type="checkbox"/>	600VAC <input type="checkbox"/>	

2) Output voltage

Single phase	(2 wire + ground)	120VAC <input type="checkbox"/>	208VAC <input type="checkbox"/>	277VAC <input type="checkbox"/>	347VAC <input type="checkbox"/>
Single phase	(3 wire + ground)	120/240VAC <input type="checkbox"/>	120/277V <input type="checkbox"/>		
Three phase	(4 wire + ground, Y)	120/208VAC <input type="checkbox"/>	277/480VAC <input type="checkbox"/>	347/600VAC <input type="checkbox"/>	

3) System capacity

KVA rating: _____

a) Please consider total power consumption of the complete fixture, not just the lamp wattage

b) Even if the systems can run with 100% load, it is recommended as standard practice to use a system with a capacity at least 20% over maximum connected load

4) Runtime

30 minutes 60 minutes 90 minutes 120 minutes

Other _____

5) Type of loads

Incandescent Fluorescent L.E.D.

Others _____

6) Mode of operation

Normally ON (24/7) Normally OFF (emergency only)

7) output circuit breakers

# of CB _____	Amps _____	# of poles _____	Normally "On" <input type="checkbox"/>	Normally "Off" <input type="checkbox"/>	Trip alarm <input type="checkbox"/>
# of CB _____	Amps _____	# of poles _____	Normally "On" <input type="checkbox"/>	Normally "Off" <input type="checkbox"/>	Trip alarm <input type="checkbox"/>

8) Options (refer to available options for each system type)

- | | |
|--|--|
| <input type="checkbox"/> (-A) 12 Hour Fast Recharge | <input type="checkbox"/> (-K) Anchor Mounting Kit |
| <input type="checkbox"/> (-C) Remote Summary Alarm Panel | <input type="checkbox"/> (-L) Drip Shield |
| <input type="checkbox"/> (-E) Output Trip Alarm | <input type="checkbox"/> (-M) Second Output Terminal Block |
| <input type="checkbox"/> (-G) Inverter On Dry Contacts | <input type="checkbox"/> (-N) Normally On & Normally Off outputs |
| <input type="checkbox"/> (-H) Normally Off Output | |
| <input type="checkbox"/> (-I) Extended Battery Warranty | |
| <input type="checkbox"/> (-J) External Maintenance Bypass Switch | |

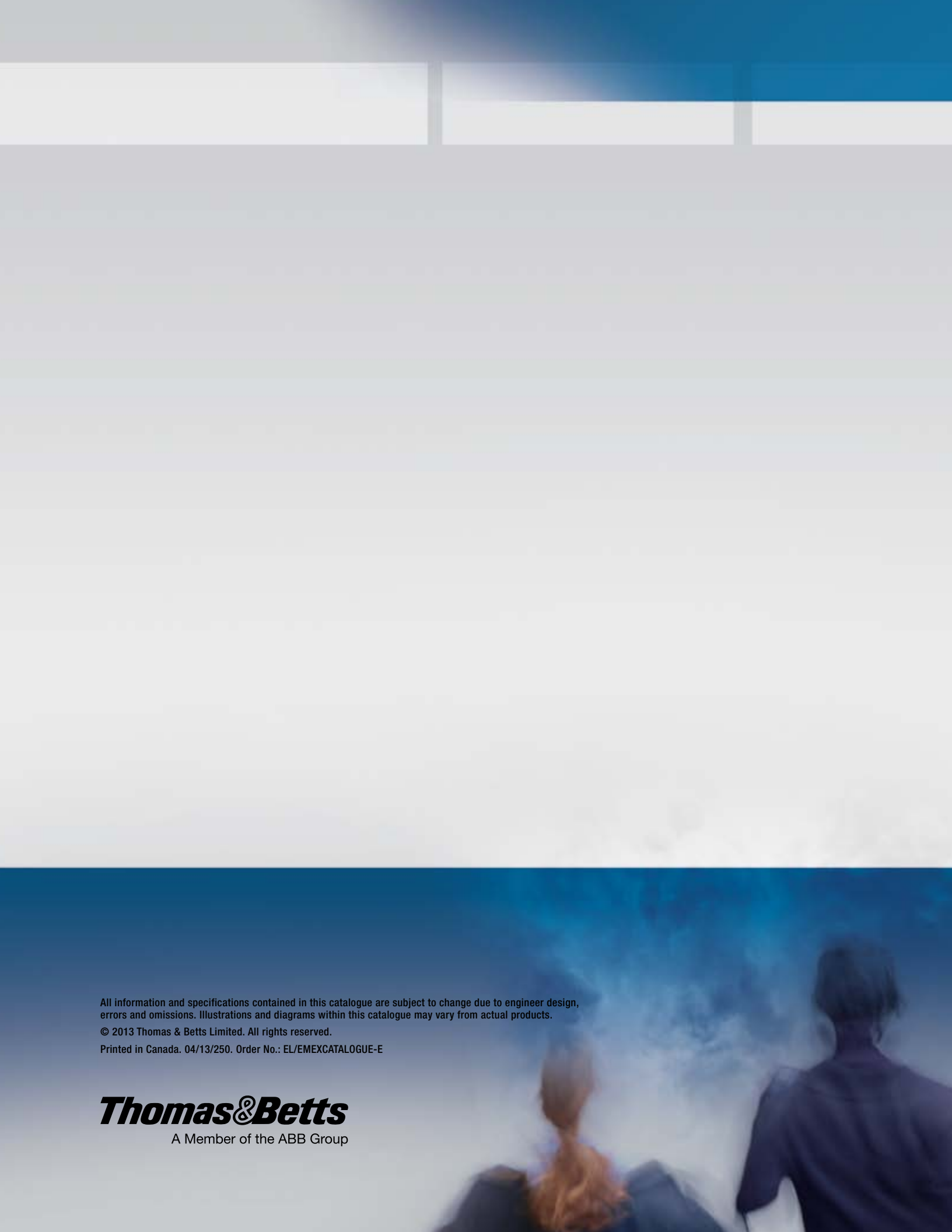

All information and specifications contained in this catalogue are subject to change due to engineer design, errors and omissions. Illustrations and diagrams within this catalogue may vary from actual products.

© 2013 Thomas & Betts Limited. All rights reserved.

Printed in Canada. 04/13/250. Order No.: EL/EMEXCATALOGUE-E

Thomas & Betts

A Member of the ABB Group