



**new** product

# MINI-INVERTER SERIES

Interruptible Unit Equipment

Project/Location: \_\_\_\_\_

Contractor: \_\_\_\_\_

Date: \_\_\_\_\_

Prepared by: \_\_\_\_\_

The **Mini-Inverter** is a cUL Listed stand-alone pure sine wave output inverter designed to provide power to designated emergency lighting fixtures. In a power loss situation, it will supply power from the onboard battery supply.

The **Mini-Inverter** works in conjunction with incandescent, LED, and fluorescent fixture types and will automatically run switched, normally-on, or normally-off designated emergency fixtures.

The **Mini-Inverter** is ideal for applications requiring an emergency source for lighting arrangements that utilize multiple lamp and fixture types and is available in surface mount and comes with a one year warranty and nine-year pro-rata battery warranty.

## FEATURES

- Lamps operated: Incandescent LED, fluorescent lamps and ballast combinations, including TRIAC dimmable ballasts
- Components: High-efficiency pure sine wave inverter
- Temperature-compensated charger 12V oversized Valve Regulated lead acid (VRLA) battery
- Construction: 18-gauge steel for 300W & 600W/ 14-gauge steel for 1000W & 1440W with a white baked-on powder coat paint finish
- Emergency lighting supplied from one convenient, reliable source
- Input/Output voltage 120/120V 60Hz or 347/347V 60 Hz
- Replaceable output fuse protection
- Valve Regulated Lead Acid (VRLA) battery provides long-life and is maintenance free
- Line voltage allows for remote mounting of emergency fixtures at distances up to 1000 feet
- Low Battery Voltage Disconnect
- Unit comes standard with electronic lockout and brownout circuits
- Meets or exceeds all National Electrical Code and Life Safety Code Emergency Lighting Requirements
- Cabinet in factory white powder-coat paint finish
- **May accept load to it's full capacity when load feature power factor of 0.9 or more**
- Non audible auto-diagnostic is standard. Nexus® system interface available with an improved minimum lost load detection of 10%
- Standard lighting control override for 0-10V dimming systems
- Meets or exceeds the requirements of CSA 141-15

## ELECTRICAL CHARACTERISTICS & DIMENSIONS

POWER RATING	MAX. INPUT RATING		SINE WAVE	INSTALLATION	CABINET DIMENSIONS			NO. OF BATTERY	WEIGHT		WEIGHT W/O BATTERY	
	120VAC	347VAC			W"	H"	D"		120V	347V	120V	347V
300W	3.10	n/a	Pure	Wall	27"	12.2"	7.3"	1	55 lbs	n/a	30 lbs	n/a
600W	6.00	2.30	Pure	Wall	24"	20"	10.5"	2	105 lbs	117 lbs	55 lbs	67 lbs
1000W	11.60	3.60	Pure	Wall	24"	20"	14.5"	2	150 lbs	169 lbs	70 lbs	89 lbs
1440W	15.00	5.00	Pure	Wall	24"	20"	14.5"	2	190 lbs	214 lbs	75 lbs	99 lbs

## TYPICAL SPECIFICATIONS

Emergency lighting shall be provided by inverter unit equipment designed to operate designated incandescent, fluorescent and LED fixtures on emergency power at their full nominal lumen rating during the full 30 minute emergency discharge cycle. System output will be rated at \_\_\_\_\_ watts for 30 minutes and provide fused output connections to the load. The system's voltage rating shall be \_\_\_\_\_ VAC input/output nominal. The inverter unit shall allow for fused connected emergency fixture(s) to be normally on, normally off, switched or dimmed without affecting lamp operation during a power failure.

Upon utility power loss, the inverter unit shall deliver 100% of its rated output to the emergency fixtures regardless of the local switch or dimmer (TRIAC) position, and will provide power to emergency fixtures at distances of up to 1000 feet. The housing shall be manufactured using 18-gauge steel for 300W & 600W/ 14-gauge steel for 1000W & 1440W with a white baked-on powder coat paint finish.

The unit's electronics shall include a self-contained inverter section with a fully automatic, thermalcompensating variable-rate battery charger, AC lockout feature, low battery voltage disconnect, overload, short circuit and brownout protection as standard. The unit shall utilize a sealed lead acid battery with a 10-year design life. The inverter system shall be cUL Listed and labeled. The unit shall be covered under a 1-year warranty on the electronics and battery and a 9-year pro-rata warranty on the battery. It shall meet or exceed the requirements of CSA 141-15.

## SPECIFICATIONS

<b>TRANSFER TIME:</b> less than 1 second
<b>VOLTAGE REGULATION ON EMERGENCY:</b> + 3%
<b>FREQUENCY REGULATION ON EMERGENCY:</b> 60 Hz +/- 1%
<b>LOAD POWER FACTOR RANGE:</b> 0.9 leading to 0.9 lagging
<b>OPERATING TEMPERATURE:</b> 20° TO 30°C (68° TO 86°F)

## WARRANTY

All **Emergi-Lite®** inverter products receive 100% quality inspection before shipment to insure proper and satisfactory operation. When operated under normal conditions, **Emergi-Lite®** inverter products will provide years of dependable service. This unit is backed by a complete 1-year warranty against defects in material or workmanship, and a 9-year prorata battery warranty.

The inverter unit is **Emergi-Lite®** model: \_\_\_\_\_.



Project/Location: \_\_\_\_\_

Contractor: \_\_\_\_\_

Date: \_\_\_\_\_

Prepared by: \_\_\_\_\_

**new** product

# MINI-INVERTER SERIES

Interruptible Unit Equipment



## WIRING DIAGRAM

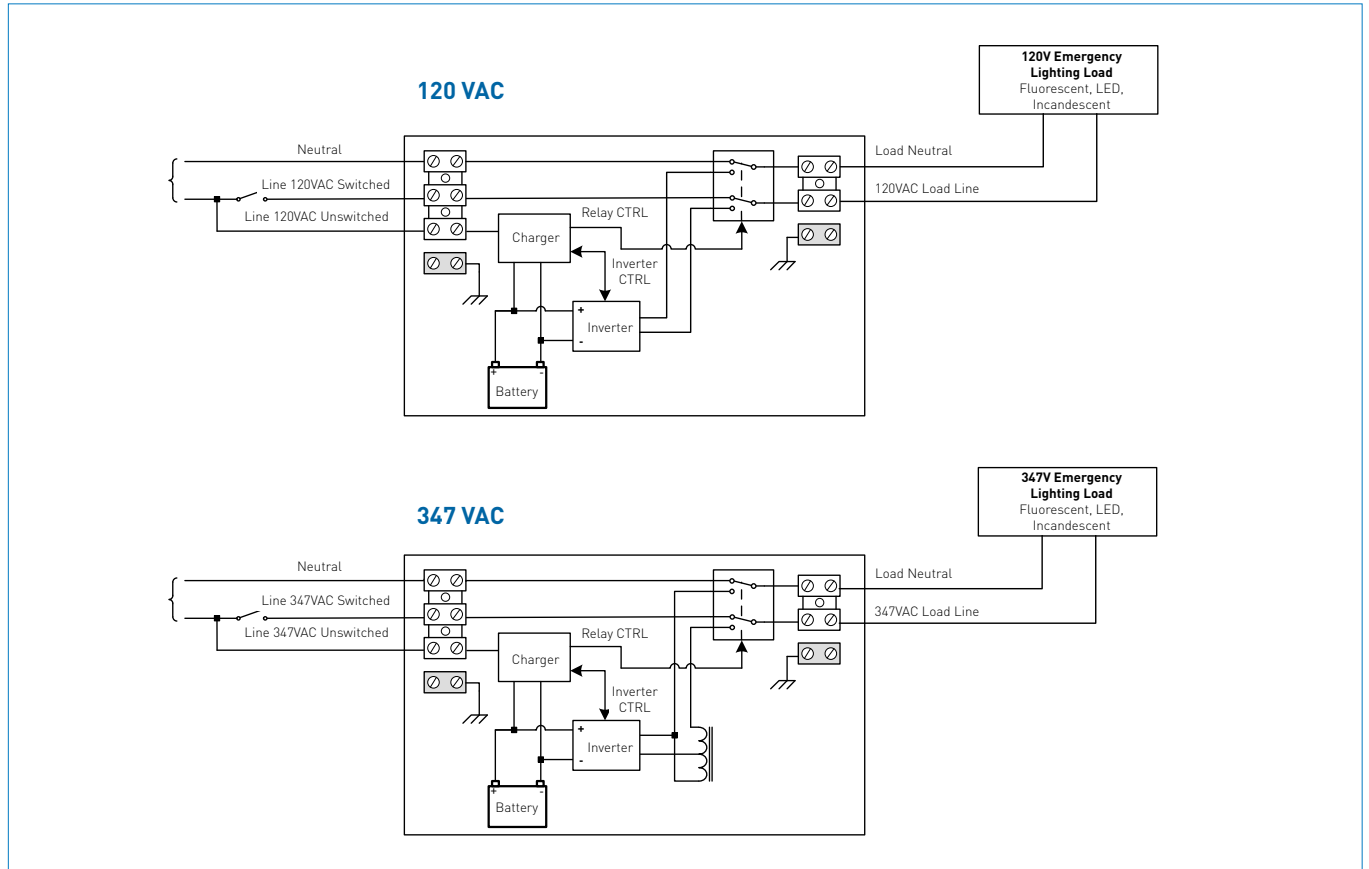

## POWER CONSUMPTION AND UNIT RATING

MODEL NUMBER	AC SPECS		EMERGENCY POWER AVAILABLE FOR LOAD				
			30MIN	1H00	1H30	2H00	4H00
EMI-300	120VAC	3.10 Amps	300W	175W	125W	100W	50W
EMI-600	120 / 347VAC	6.00 / 2.30 Amps	600W	350W	250W	200W	100W
EMI-1000		11.60 / 3.60 Amps	1000W	585W	415W	330W	165W
EMI-1440		15.00 / 5.00 Amps	1440W	842W	600W	480W	240W

## ORDERING INFORMATION

SERIES	CAPACITY	VOLTAGES IN/OUT	DIAGNOSTIC FEATURES	OPTIONS
EMI= Series	-300= 300W -600= 600W -1000= 1000W -1440= 1440W	-1= 120/120VAC, 60 Hz -3= 347/347VAC, 60 Hz*	Blank= Auto-Diagnostics, non-audible* -U= Auto-Diagnostics, audible* -NEX= Nexus® wired system interface** -NEXRF= Nexus® wireless system interface**	-D3= Time Delay (15 minutes) -LC= Line Cord (120V only) -LW= Twist Lock Plug (120V only) -SAC= Service alarm contact*
		* Available only with 600W, 1000W & 1440W	* Minimum load required: 10% of unit capacity ** Please consult your sales representative	* Not available with 1000W & 1440W capacities

EXAMPLE: EMI-1440-1