



NEW features

HZM SERIES

Battery Unit Hazardous
Locations: Class I Div 2,
Class II Div 1&2 and Class III

Type: _____
Project/Location: _____
Contractor: _____
Prepared By: _____
Date: _____
Model No.: _____

FEATURES

- n** • Includes the addition of Class II Div 1&2 Groups E, F and G as well as Class III ratings
- Certified Class I Zone 2, Groups IIA, IIB and IIC
- Certified Class I Division 2, Groups A, B, C and D as per CSA C22.2 No.137-M1981
- Certified temperature codes for several types of emergency lamps
- Suited for areas with the risk of flammable gases, vapors or liquids that can create an explosive atmosphere
- Certified CSA C22.2 No141
- Polymeric frame, with built-in gasket to prevent water infiltration
- Heavy-duty 1/8" thick aluminum back plate with keyholes for secure wall-mount installation
- Two MR16 halogen or LED lamps, shielded by a cast aluminum housing and a polycarbonate cover
- 5W LED emergency lights provide 60 ft of egress illumination on a 6-foot wide path
- n** • 6W LED emergency lights provide 100 ft of egress illumination on a 6-foot wide path
- Sealed, maintenance-free, Lead-Calcium batteries with up to 150W emergency power
- Built-in microcontroller-based battery charger and auto-diagnostics circuitry
- 1/2" electrical conduit entry on both sides and at the top
- NEXUS® compatible [for more information on NEXUS®, please contact your sales representative]

TYPICAL SPECIFICATIONS

Supply and install **Emergi-Lite® HZM Series** battery units. Designed specifically for Hazardous Location environments, the equipment frame shall be of industrial grade polymeric material with gaskets around both sides of the contour. The frame shall be fixed between two plates made of 1/8" thick aluminum sheet. The back plate shall include four keyholes for wall-mount installation. The front plate shall include two water-tight lenses for pilot lights: AC-on and "Service required". When specified, the equipment shall have attached a lower compartment containing two emergency lights with adjustable swivels and MR-16 halogen lamps. The lamps shall be shielded by a cast aluminum housing and protected by a shock-absorbent, transparent polycarbonate cover. The equipment shall be certified for Hazardous Locations: Class I Division 2 Groups A, B, C and D, Class II Division 1&2 Groups E, F and G as well as Class III. The standard equipment shall have a dual voltage input: 120/347VAC and shall be equipped with a magnetic test switch located on the left side of the frame.

The unit shall include self-testing/auto-diagnostic functions monitored by a micro-controller and shall automatically self test for one minute every 30 days, 10 minutes every 6 months and 30 minutes annually. The "Service required" LED shall light when a fault is detected. A four-LED diagnostic display located inside the equipment shall identify the source of the failure (battery, charger circuitry, lamp load).

The unit shall be listed CSA C22.2 No.141 and No. 137 - M1984
The battery unit shall be **Emergi-Lite®** model: _____.



HAZARDOUS LOCATION FAMILY CLASS I, II AND III



EH P. 66



LPEXHZ P. 65



EHC Combo P. 68-69



EXHZ Combo P. 70-71



EF41 Remote P. 154

TEMPERATURE CODES (CLASS I DIVISION 2)

LAMP RATING	TEMPERATURE CODE	MAX. TEMPERATURE	REPLACEMENT LAMP
6V-10W	T3C	160°C	580.0079-EL
12V-12W	T3A	180°C	580.0080-EL
12V-20WH	T2D	215°C	580.0068-EL
6V-4W LED	T4A	120°C	580.0097-EL
12V-4W LED	T4A	120°C	580.0093-EL
12V-5W LED	T4A	120°C	580.0104-EL
12V-6W LED	T4	135°C	580.0106-EL

Note: Use qualified replacement lamps to avoid risk of over-heating.

POWER CONSUMPTION AND UNIT RATING

MODEL	AC SPECS		WATTAGE CAPACITY				
			30 MIN	1H00	1H30	2H00	4H00
HZM36	120/347VAC	0.15/0.06 A	36	21	15	12	-
HZM72		0.30/0.10 A	72	42	30	24	12
HZM120		0.30/0.10 A	120	70	50	40	20
HZM150		0.30/0.10 A	150	-	72	-	-

Type: _____
 Project/Location: _____
 Contractor: _____
 Prepared By: _____
 Date: _____
 Model No.: _____

HZM SERIES

Battery Unit Hazardous Locations: Class I Div 2, Class II Div 1&2 and Class III



DIMENSIONS

Dimensions are approximate and subject to change.

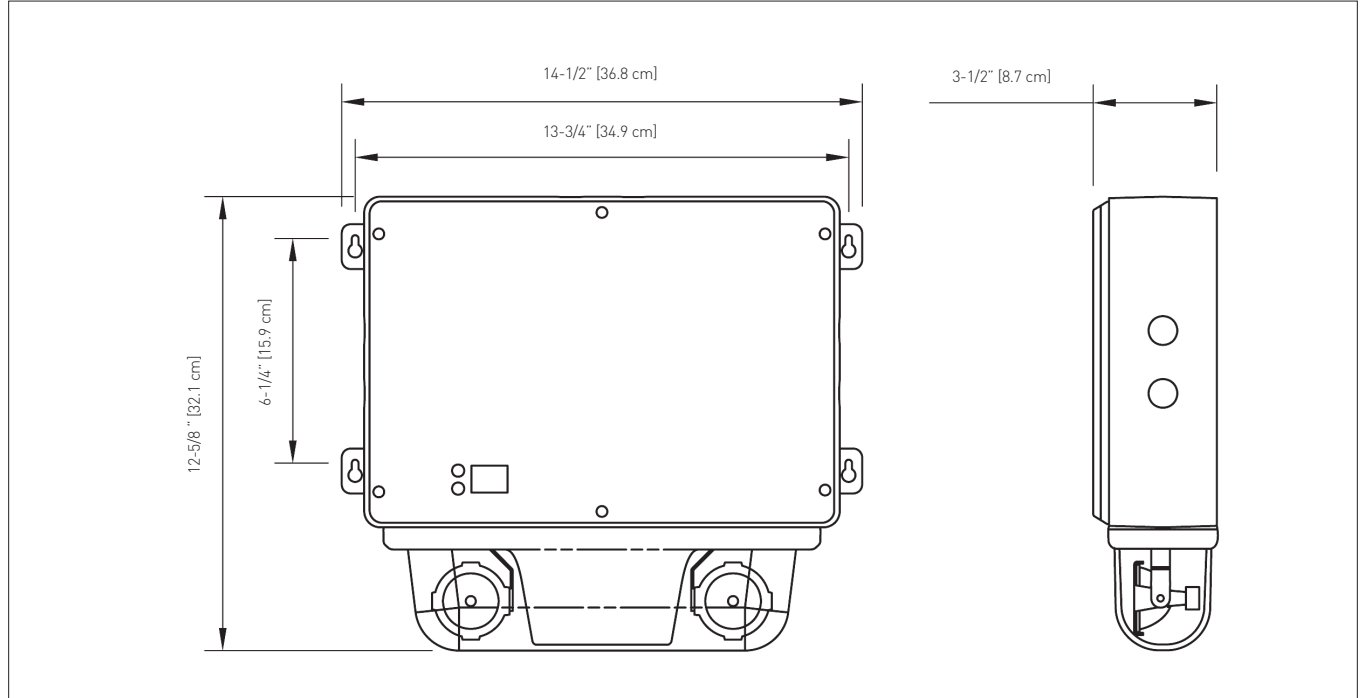

ORDERING INFORMATION

SERIES	CAPACITY	COLOUR	AC VOLTAGE	OPTIONS	NUMBER OF HEADS	LAMP/WATTAGE
06HZM 12HZM	36= 6V-36W 72= 12V-72W 120= 12V-120W 150= 12V-150W	Blank= grey	Blank= 120/347VAC -2= 277VAC	U= auto-diagnostics, audible* UN= auto-diagnostics, non-audible* NEX= NEXUS® system Interface* NEXRF= wireless NEXUS® system interface*	/0= no heads /2= 2 heads	LA= MR16 LED, 6V-4W LG= MR16 LED, 12V-4W LI= MR16 LED, 12V-5W LJ= MR16 LED, 12V-6W MJ= MR16, 6V-10W MK= MR16, 12V-12W MW= MR16-IR, 12V-20W, high output
<p>* Minimum lamp load required: 20% of unit capacity * Not all options available with NEXUS® System. Please consult your sales representative</p>						

EXAMPLE: 06HZM36UN/2MJ