



new product

RG-X "Picto" Series

Battery Units, Self-Powered Pictogram Exit Signs, Combination Units

Type: _____

Project/Location: _____

Contractor: _____

Prepared By: _____

Date: _____

Model No.: _____

CSA certified for use in hazardous locations

The **RG-X Pictogram Exit Series** of battery equipment is designed to cover emergency lighting applications for the entire spectrum of hazardous locations, where inflammable gases, vapors, liquids, dust particles or fabrics tissues are permanently present or are likely to exist.

The **RG-X Pictogram Exit Series** combines in one simple-to-order catalogue family three traditional emergency lighting products with battery back-up: battery units with emergency lights, Self-Powered Pictogram Signs, and combination units with emergency lights and Pictogram Sign. The equipment is also available with additional emergency power capacity to drive remote heads and Pictogram Signs.

FEATURES

- CSA Certified for use in hazardous locations:
 - Class I, Divisions 1 and 2, Groups B, C, D
 - Class II, Divisions 1 and 2, Groups E, F, G
 - Class III, Divisions 1 and 2
- Die-Cast aluminum body with grey epoxy powder coat finish; clear, impact and heat resistant prismatic glass globe
- Long-life, maintenance-free lead-calcium battery
- Battery charger is current limited, temperature compensated, short-circuit proof and reverse polarity protected
- Emergency heads with one or twin lamp design
- Self-Powered combo includes a transfer circuit to drive an additional five (5) remote pictogram exit signs (total power max 25W)
- Easy-to-build catalogue number based on the **Lumacell®** Severity Codes
- Also available as Pictogram Exit Signs and remote fixtures; refer to the LX and RS10XP catalogue sheets
- Meets or exceeds CSA 22.2 No.141-15



See warranty details at: www.tnb.ca/en/brands/lumacell

DIMENSIONS

Dimensions are approximate and subject to change.

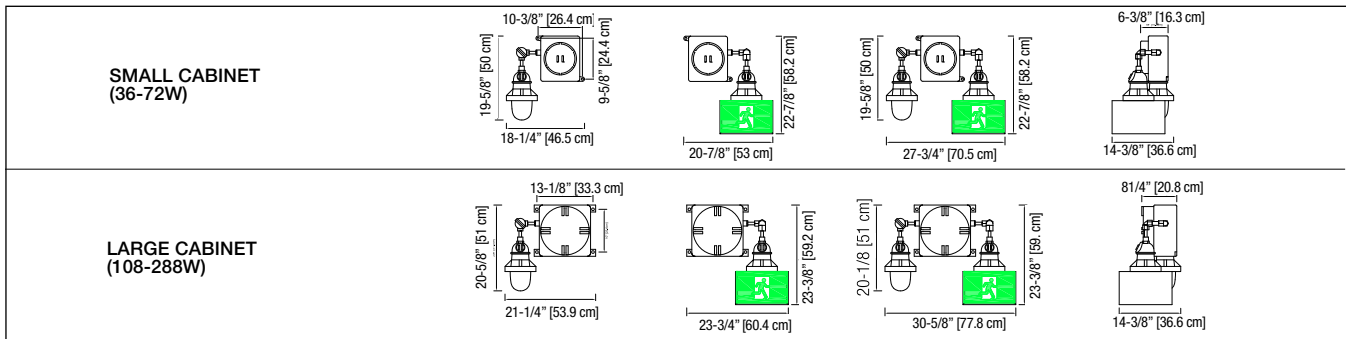

TYPICAL SPECIFICATIONS

Supply and install the **Lumacell® RG-X Pictogram Exit Series** of hazardous location battery equipment. The battery unit housing will be constructed of die cast aluminum with grey epoxy powder coat finish. The equipment shall be rated for 120, 277 or 347V, 60 Hz input and be CSA listed. The equipment shall have an output of _____ V and _____ W and shall supply the rated load for a minimum of a 1/2 hour to 87,5% of the rated battery voltage. The battery shall be a long-life, maintenance-free lead-calcium type. The charger shall be fully computer tested and have its charge voltage set in the factory to ± 1% tolerance. The charger shall be current limited, temperature compensated, shortcircuit proof and reverse polarity protected. The charger shall be furnished with an electronic lockout circuit, which will connect the battery when the AC circuit is activated, and an electronic brownout circuit, which will activate the emergency heads when the utility power dips below 75% of nominal voltage.

Where required the equipment shall come complete with _____ heads, each of them equipped with _____ lamp(s) of _____ W. The head housing shall be Die-Cast aluminum with grey epoxy powder coat finish. The lenses shall be a clear, impact and heat resistant prismatic glass globe. The head shall be factory sealed, with no need for external seals.

Where required the equipment shall come complete with one Pictogram Exit Sign and will include a transfer circuit to maintain the Pictogram Sign permanently lighting in both normal and emergency operation. The picto housing shall be industrial grade 14-gauge steel and finished in grey enamel. The faceplate will be constructed of heavy-duty 14-gauge steel and feature universal knockout chevrons and the red letters shall not be less than 6" (150 mm) in height with a 3/4" (19 mm) stroke. The sign shall include a LED lamp with **ALINGAP** LEDs and shall consume less than 5W in either AC or battery mode. The equipment shall be certified CSA 2.22 No.137-M1981 for Hazardous Locations: Class _____, Division _____, Group _____ with the temperature code _____.

The Pictogram Exit Sign shall be CSA 22.2 No.141-15 certified.

The equipment shall be **Lumacell®** Model: _____ .

POWER CONSUMPTION AND UNIT RATING

MODEL	AC SPECS	WATTAGE CAPACITY					
		30MIN	1H00	1H30	2H00	4H00	
RG6V36X	120/347VAC	0.50/0.20 A	36	21	15	12	6
RG6V72X		0.50/0.20 A	72	42	30	24	12
RG6V108X		0.50/0.20 A	108	63	45	36	18
RG12V72X		0.50/0.20 A	72	42	30	24	12
RG12V144X		0.50/0.20 A	144	84	60	48	24
RG12V200X		0.50/0.20 A	200	117	83	67	33
RG24V144X		0.50/0.20 A	144	84	60	48	24
RG24V288X		0.50/0.20 A	288	168	120	96	48

NOTE : The wattage capacity applies only to the battery unit. For combo or Self-Powered Exit Signs one must allocate 5W of emergency power for each sign.

Type: _____
 Project/Location: _____
 Contractor: _____
 Prepared By: _____
 Date: _____
 Model No.: _____



new product

RG-X "Picto" Series

Battery Units, Self-Powered
Pictogram Signs,
Combination Units



TEMPERATURE CODES: MEASURED AT 40°C AMBIENT

Explosion-proof equipment is composed of one or more modules, each of them qualified for a specific temperature code. The temperature code of the complete equipment (enclosure + exit sign + emergency heads) is defined as the most severe of the temperature codes identified for each of the modules below.

1. TEMPERATURE CODES FOR RG-X SERIES (BATTERY UNIT ENCLOSURE)

SEVERITY CODE	S1	S2	S3	S4
TEMPERATURE CODE	T6	T6	T6	T6

2. TEMPERATURE CODES FOR LX SERIES* (PICTOGRAM EXIT SIGN)

SEVERITY CODE	S1	S2	S3	S4
TEMPERATURE CODE	T6	T6	T4A	T6 (E, F, G)

*Self-Powered Pictogram Exit Sign only (no heads).

3. TEMPERATURE CODES FOR RS10XP SERIES (EMERGENCY HEADS)

SEVERITY CODE	QUARTZ BI-PIN 12W, 20W	MR16 12V-12W	MR16 12V, 24V-20W	MR16 12V, 24V-35W	MR16 12V, 24V-50W	MR16 120V-20W	MR16 120V-35W	MR16 120V-50W
S1	T5 (100°C)	T6 (85°C)	T5 (100°C)	T4A (120°C)	T3C (160°C)	T5 (100°C)	T3A (180°C)	T3 (200°C)
S2	T5 (100°C)	T6 (85°C)	T5 (100°C)	T4A (120°C)	T3C (160°C)	T5 (100°C)	T3A (180°C)	T3 (200°C)
S3	T1 (450°C)	T4 (450°C)	T3 (200°C)	T2 (300°C)	T1 (450°C)	T2D (215°C)	T2 (300°C)	T1 (450°C)
S4	T4A (120°C) (E,F,G)	T5 (100°C) (E,F,G)	T5 (100°C) (E,F,G)	T4A (120°C) (E,F,G)	T3C (160°C) (E,F,G)	T4A (120°C) (E,F,G)	T3C (160°C) (E,F,G)	N/A

ORDERING INFORMATION

Before ordering, identify the environment of your application: Class _____, Division _____, Group _____. Refer to the table 1 for the Severity Code to use in your catalogue number. For temperature information, please look at the table 2.

4. SEVERITY CODE SELECTION CHART

ENVIRONMENT	SEVERITY CODE
Cl. I, Div. 1&2, Gr. B	S1
Cl. I, Div. 1, Gr. C, D	S2
Cl. I, Div. 2, Gr. B, C, D	S3
Cl. II, Div. 1 & 2, Gr. E, F, G Cl. III, Div. 1 & 2	S4

RG-X

SERIES	DC VOLTAGE	CAPACITY CABINET SIZE	HOUSING	FACES	HEAD STYLE	LAMPS	SEVERITY CODE	AC VOLTAGE	OPTIONS
RG	6= 6V	36= 36W [S]* 72= 72W [S]* 108= 108W [L]*	X= hazardous location	Blank= no exit sign RP1= single face RP2= double face	0= no heads A1= single remote, 1 lamp A2= single remote, 2 lamps A3= double remote, 1 lamp	Blank= no lamp 12W= halogen, 6V, 12V, 12W, bi-pin 20W= halogen, 6V to 24V-20W, bi-pin M12W= MR16 halogen, 12V-12W M20W= MR16 halogen, 12V, 24V-20W M35W= MR16 halogen, 12V, 24V-35W M50W= MR16 halogen, 12V, 24V-50W MH20W= MR16-IR 12V-20W, high output MH35W= MR16-IR 12V-35W, high output MH50W= MR16-IR 12V-50W, high output	S1= CL.1, Div1&2, Gr. B S2= CL. 1, Div.1&2, Gr. C, D S3= CL. 1, Div.2, Gr. B, C, D S4= CL. II, Div.1 & 2 Gr. E, F, G, CL. III, Div 1 & 2	Blank= 120VAC ZC= 277VAC input ZD= 347VAC input	Blank= no options TD= time delay TP= transfer panel
	12= 12V	72= 72W [S]* 144= 144W [L]* 200= 200W [L]*							
	24= 24V	144= 144W [L]* 288= 288W [L]*							
		* Cabinet size is not part of nomenclature							

EXAMPLE: RG636XA112WS1